

SWING CLAMPS W/ TORQUE CONTROL - MINIATURE

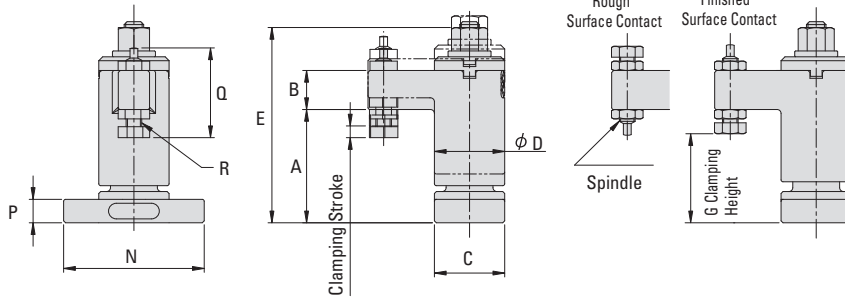

How To Use

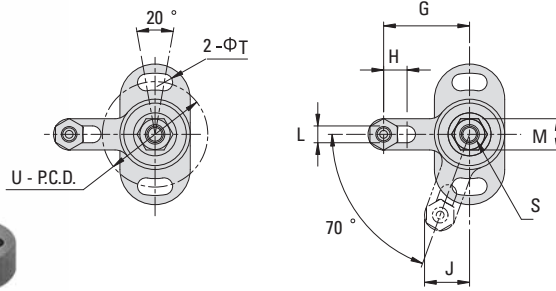
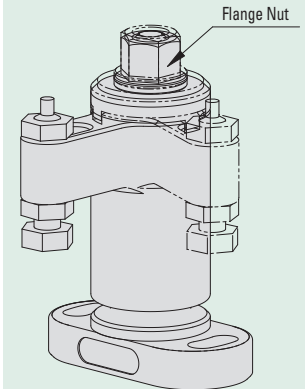

Turning the flange nut allows the arm to swing into position for clamping.

Warning

To prevent damage, do not use power tools (impact wrench) to turn the flange nut.

These miniature clamps swing into position and clamp straight down onto the work piece for direct downward pressure. The arm swings completely out of the way to allow for easy loading and unloading of the work piece. The flange nut is used to activate the swing arm and allows the user to apply precise pressure by using a torque wrench or a removable handle to avoid interference. Ideal for applications where precise clamping force is required to avoid part distortion. Comes with a contact bolt that can be reversed for finished or rough surfaces. Mounts from the top with two mounting holes. The QLSWC-05 provides up to 517 lbs of clamping force, the QLSWC-06 provides up to 809 lbs of clamping force. The clamp arm swings out of the way in a counter clockwise direction. The body, washer, flange nut and spindle are made from SAE-1045 alloy steel. The clamping arm is made from SAE-4140 alloy steel. Parts are heat treated with black oxide finish.

Part #	Clamping Height		Clamping Stroke	Allowable Screw Torque (in/lbs.)
	Finished Surface	Rough Surface		
QLSWC-05	22.8 - 27.8	22.4 - 27.4	3.0	53
QLSWC-06	31.3 - 37.3	32.2 - 38.2	4.0	92

Part #	A	B	C	D	E	G	H	J	L	M	N	P	Q	R	S	T	P.C.D.* U
	mm	mm	mm	mm	mm	mm	mm	mm	mm	mm	mm	mm	mm	mm	mm	mm	mm
QLSWC-0618	29	10	18	18	56.5	22	6	11.5	4.3	10	36	6	22.8	M4X0.7	M6X1	4.3	27
QLSWC-0823	39	14	23	23	73.5	30	8	15.3	5.3	13	45	8	28.5	M5X0.8	M8X1.25	5.3	34

*Pitch Circle Diameter