

DISC HAND WHEELS

Aluminum | Without Machine Handle | Inch and Metric

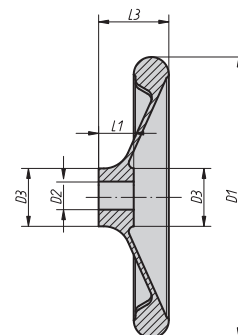
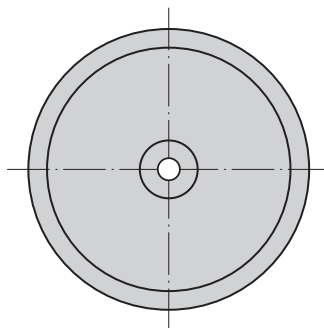

These Hand Wheels are made from aluminum. The rim is turned and polished. The center bore is concentric and parallel with the outside of the handle.

INCH

Part #	D2	Part #	D2	D1	D3	L1	L3
06279-0080XCN	.312	06279-0080XCO	.375	3.15	.94	.63	1.18
06279-0100XCO	.375	06279-0100XCP	.500	3.94	.98	.67	1.22
06279-0120XCO	.375	06279-0120XCP	.500	4.72	1.02	.71	1.26
06279-0160XCP	.500	06279-0160XCQ	.625	6.30	1.30	.79	1.57
06279-0200XCQ	.625	06279-0200XCR	.750	7.87	1.54	.94	1.65
06279-0250XCR	.750	06279-0250XCV	.875	9.84	1.89	1.10	2.36
06279-0280XCR	.750	06279-0280XCV	.875	11.02	1.93	1.18	2.52
06279-0360XCV	.875	06279-0360XCS	1.00	14.17	2.48	1.38	2.83

METRIC

Part #	D2 mm	Part #	D2 mm	D1 mm	D3 mm	L1 mm	L3 mm
06279-0080X10	10	06279-0080X12	12	80	24	16	30
06279-0100X10	10	06279-0100X12	12	100	25	17	31
06279-0120X12	12	06279-0120X14	14	120	26	18	32
06279-0160X14	14	06279-0160X16	16	160	33	20	40
06279-0200X18	18	06279-0200X22	22	200	39	24	42
06279-0250X22	22	06279-0250X26	26	250	48	28	60
06279-0280X24	24	06279-0280X28	28	280	49	30	64
06279-0360X28	28	06279-0360X32	32	360	63	35	72