

L

PTFE-PFA FLOW METERS

Incorporating the principles of traditional rotameter flow technology, these rugged PTFE-PFA flow meters offer solutions to low to medium flow range measurements of highly corrosive or ultra-pure liquids.

Wetted inert components are surrounded by structurally rigid materials such as PFA-clad aluminum, KYNAR®. The resultant design represents a unique combination of a rugged mechanically rigid frame and the chemically inert wetted parts. *Model L* Meters are constructed of inert materials such as PFA, PTFE and PCTFE.

Flow meters are also resistant to external, ambient corrosives.

For the protection of personnel each flow meter is supplied with a safety shield.

Flow meters are supplied with or without built-in needle valves and they are panel mountable, by means of KYNAR® panel nuts.

design features

- ✓ Chemically inert wetted components constructed from PFA PTFE and PCTE.
- ✓ Non-fluid contacting structurally rigid frame constructed from PFA-clad aluminum and KYNAR®.
- ✓ Overlapping flow ranges are available for water from 5 mL/min (0.00132 GPM) to 45 L/min (12 GPM).
- ✓ Individually leak tested.

LEAK INTEGRITY

Flow meters are individually tested on a Mass Spectrometer Leak Detector and certified to a leak integrity rating of 1×10^{-7} sccs Helium or better.

High Range PTFE meter with Valve

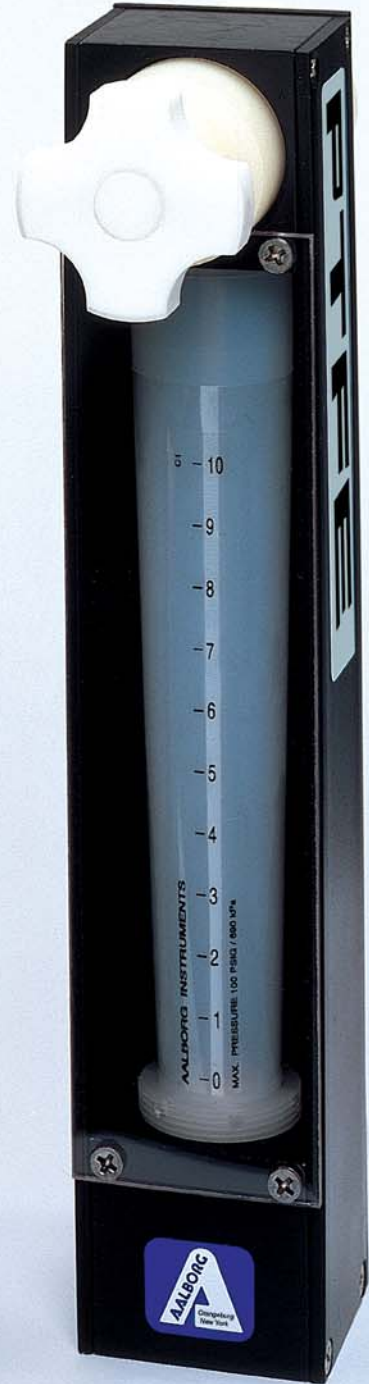

Low Range PTFE meter without Valve



PRINCIPLES OF OPERATION

A cylindrical float freely moving inside a tapered flow tube comprises the flow measurement element of PTFE - PFA flow meters. The translucent PFA flow tube is installed vertically in-line in the liquid stream.

As flow takes place the float is propelled up inside the flow tube. The area between the float and the inside diameter of the flow tube gradually increases with increasing flow and correspondingly the pressure lifting the float decreases until the weight of the float and its buoyant force come to equilibrium.

At equilibrium the top of the float is lined up with a scale graduation on the flow tube denoting a discrete rate of flow.

MOUNTING DIMENSIONS

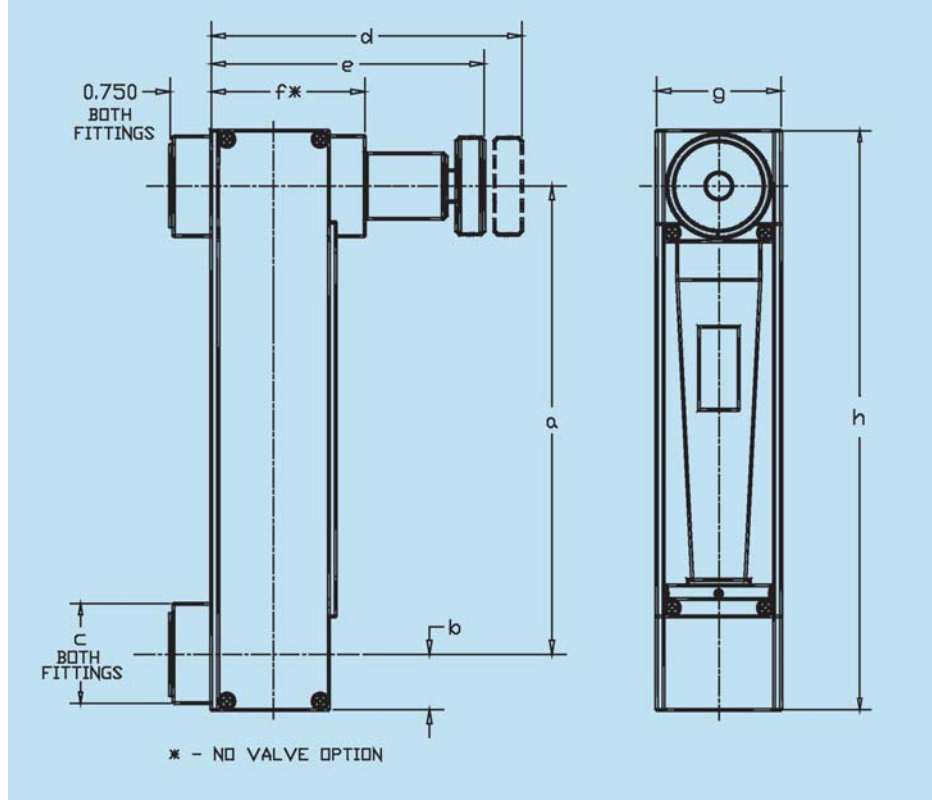

SPECIFICATIONS	
SCALES	0 to 10 markings (see dimension table for scale lengths).
ACCURACY	±5% of full scale.
MAXIMUM TEMPERATURE	250° F (121°C).
MAXIMUM PRESSURE	100 psig (6.7 bars).
LEAK INTEGRITY	Individually pressure and leak tested and certified to a rating of 1 x 10 ⁻⁷ sccs of Helium.

** MATERIALS OF CONSTRUCTION	
FLOW TUBES	PFA.
FLOATS	PTFE.
WETTED PARTS	PFA (flow tubes) and PTFE (end fittings and floats) and PCTFE (guide rods).

**The selection of materials of construction, is the responsibility of the customer. The company accepts no liability.

DIMENSIONS FOR L STYLE METERS									
METER SIZE	A	B	C	D	E	F	G	H	SCALE LENGTH
C	4.97	0.56	1.06	3.35	3.15	1.52	1.25	6.16	75mm
D	4.97	0.56	1.25	4.65	4.25	1.82	1.50	6.16	75mm
E	8.72	0.88	1.75	4.57	4.07	2.12	2.00	10.4	125mm
F	8.47	1.00	1.75	5.95	5.00	2.32	2.25	10.4	125mm

* Dimensions are in inches, except as shown in [mm]; for certified dimensions contact the company.

ORDERING INFORMATION				
L STYLE LOW RANGE METERS				
MODEL NUMBER		CONNECTION	MAXIMUM FLOW	
BUILT IN VALVE	NO VALVE		[mL/min] WATER	[gph] WATER
L6C-L01-01-SA	L3C-L01-01-SA	1/4" FNPT	75	1.19
L6C-L02-01-TF	L3C-L02-01-TF	1/4" FNPT	250	3.96
L6C-L03-01-TF	L3C-L03-01-TF	1/4" FNPT	400	6.34
L6C-L04-01-TF	L3C-L04-01-TF	1/4" FNPT	500	7.92
L6C-L05-01-TF	L3C-L05-01-TF	1/4" FNPT	1000	15.85
L6D-L06-01-TF	L3D-L06-01-TF	3/8" FNPT	2000	31.69
L6D-L07-01-TF	L3D-L07-01-TF	3/8" FNPT	2500	39.62
L6D-L08-01-TF	L3D-L08-01-TF	3/8" FNPT	3000	47.54
L6D-L09-01-TF	L3D-L09-01-TF	3/8" FNPT	5000	79.23

L STYLE HIGH RANGE METERS				
MODEL NUMBER		CONNECTION	MAXIMUM FLOW	
BUILT IN VALVE	NO VALVE		[L/min] WATER	[gpm] WATER
L6E-L10-01-TF	L3E-L10-01-TF	1/2" FNPT	13	3.43
L6E-L11-01-TF	L3E-L11-01-TF	1/2" FNPT	20	5.28
L6F-L12-01-TF	L3F-L12-01-TF	3/4" FNPT	30	7.93
L6F-L13-01-TF	L3F-L13-01-TF	3/4" FNPT	40	10.57
L6F-L14-01-TF	L3F-L14-01-TF	3/4" FNPT	45	11.89

BULLETIN EM201007 L