

Suspended Electromagnets

...Only from Eriez.

SE Series 7000

Automatically removes large tramp metal contamination from product flows on conveyors belts or vibratory feeders to product processing equipment and improve product purity.

Eriez, a pioneer in the development of oil-cooled suspended electromagnetic separators, offers a line of magnets for difficult, heavy duty applications. The Series 7000 electromagnets successfully remove damaging tramp metal from flows of coal, limestone, sand, gravel, municipal waste, wood products, recycled materials, other ores and almost any conveyed non-ferrous material.

The Series 7000 Suspended Magnets provide the traditional quality, performance, reliability and value of Eriez separators with added features to increase productivity and profitability.

FEATURES

- Aluminum or copper coils utilize Nomex insulation and fiberglass spacers to prevent shorts and provide exceptional coil life
- Exclusive oil expansion tank prevents condensation and protects against hot spots to extend coil life
- Manganese bottom plate provides for superior durability in rugged applications
- Five-year warranty on coil assembly — longest in the industry
- 23 magnet sizes, 69 standard models and hundreds of special designs available for your unique application
- Manual-cleaning magnets available for simple installations while self-cleaning units provide for continuous tramp metal removal
- Special features available such as elevation derated coils, high fire point coolants, conveyor speed switches, dust covers, guards, controls, permanent extensions, monitoring devices and many more for every unique application



QUALITY DESIGN AND CONSTRUCTION

The Eriez Hi-Gradient Circuit, scientifically balanced to make full use of the magnet's high permeability steel members for most efficient magnetic field distribution, produces maximum-force density at a selected working distance from the magnet face. The magnet is fabricated from heavy-steel plate with a thick, manganese, steel bottom plate. The Series 7000 magnet is structurally rugged and built to last.

Other design features include:

- Class H insulated aluminum coils.
- Space-wound coils with non-deteriorating fiberglass spacer and insulating material. No wood products are used in Eriez Series 7000 Magnets.
- An efficient four-pulley self-cleaning arrangement, plus a two-pulley design for smaller models

EXCLUSIVE EXTERNAL OIL EXPANSION TANK

This unique feature has helped prevent coil burnout on thousands of Eriez oil-cooled electromagnets.

Heat and moisture, the greatest enemies of electromagnets, are effectively controlled by the expansion tank which assures that the coils are always completely covered with cooling oil. Competitive units provide air space within the magnet housing where damaging condensation forms when moist air seeps in through the pressure relief valve as the magnet cools. Eriez' expansion tank traps this moisture and keeps it out of the magnet.

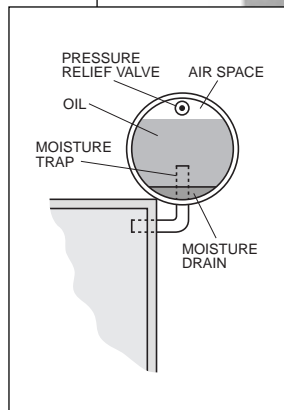

STYLES AND MODELS

MC Models (Manual Cleaning)

All MC models are cleaned of accumulated tramp iron by turning off magnet power periodically. They are recommended for use where only occasional pieces or small amounts of iron may contaminate the material flow.

- Standard mounting hardware consists of adjustable suspension sling.
- MC models can be easily converted to SC styles giving great flexibility for changing conditions.

SC Models (Self Cleaning)

SC Models provide completely automatic iron removal and can be installed in an "in line" position (SC-1) or in a "cross belt" position (SC-2). Each of the two self-cleaning configurations is designed to suit specific conditions and requirements. Space and clearance, conveyor belt speed, burden depth, tramp iron size, etc., are factors that dictate choice of style.

Both SC Models incorporate a short-belt conveyor built around the magnet to effect automatic removal of tramp iron

from the magnet face. This system features a rubber conveyor belt, bearings, rugged but simple continuous channel frame, adjustable take-ups and shaft-mounted reducer with V-belt coupling to a TEFC motor.

- Optional mounting hardware consists of turnbuckles.
- All style SC units are easily demountable from SC conveyor and can be used independently as MC units.

Options

A wide choice of options is available to assure peak performance in unique or difficult applications. Some of these are:

- Steel dust enclosures for magnet installation in dusty locations
- Explosion-proof motors
- Static-conducting belts
- Special belts for abrasive, hot or difficult applications
- Conveyor speed switches
- Magnet load monitor



HOW TO SELECT THE CORRECT SE MAGNET

The most important factors in the selection of the proper Series 7000 suspended electromagnets are burden depth, belt width, suspension position and tramp iron size. Other important considerations are listed below.

Since many factors may affect choice of the proper magnet, intelligent engineering practice dictates that each application be individually reviewed by an Eriez Sales Engineer before selection is made. The following information is required to make the proper recommendation:

- | | |
|---|---------------------------------|
| • burden depth | • belt incline |
| • belt width | • capacity (tph or cfh) |
| • suspension position | • material density |
| • tramp iron size (minimum and maximum) | • ambient temperature |
| • material size | • altitude |
| • maximum lump size | • head pulley material |
| • belt speed | • head pulley diameter |
| • degree of troughing idlers | • available current (ac and dc) |

INSTALLATION

Preferred installation of a suspended magnet is over the trajectory of material discharged from a belt conveyor. This is referred to as Position 1 installation.

If a sufficient trajectory is developed, this is the best way to utilize the full potential of the separator since the material being treated is moving directly toward the magnet face, and its momentum assists the separation of iron. At slower conveyor speeds, as the trajectory of the discharge material becomes more nearly vertical, magnet position must be shifted back more nearly over the head pulley. At slow belt speeds a nonmagnetic head pulley may be required.

Installation with the separator over the moving bed of material before the discharge point of the conveyor is referred to as Position 2 mounting.

Position 2 mounting is not recommended where belt speeds are high.

Positions 1 and 2 (Manual Cleaning/MC-1 and MC-2)

This style unit consists of the magnet only. With manual-cleaning magnets, it is necessary to periodically remove the accumulated tramp iron.

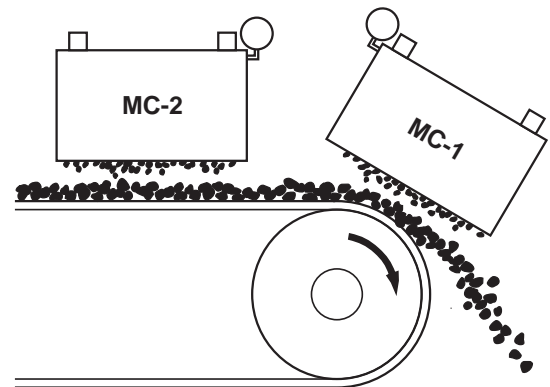

Position 1 (Self-Cleaning/SC-1)

This unit consists of magnet with a short-belt conveyor built around it to provide self-cleaning. This unit is designed to be mounted in Position 1, as illustrated, at the head end of a conveyor either over the trajectory of the discharged material or over the head pulley. It provides automatic discharge of tramp iron in the direction of the main conveyor travel.

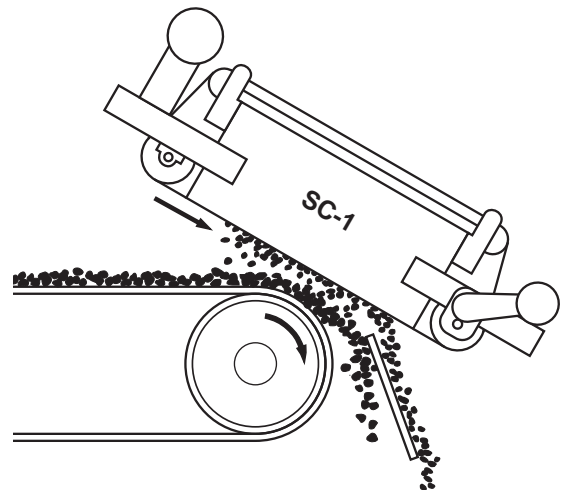

Position 2 (Self-Cleaning/SC-2)

This separator is similar to the Position 1 Self-Cleaning unit except the self-cleaning belt travels across the magnet face at right angles to the main conveyor, providing automatic tramp iron discharge at right angles to the direction of the moving material burden. It is designed for mounting in Position 2, as illustrated, over a conveyor belt, picking table, vibrating screen etc.

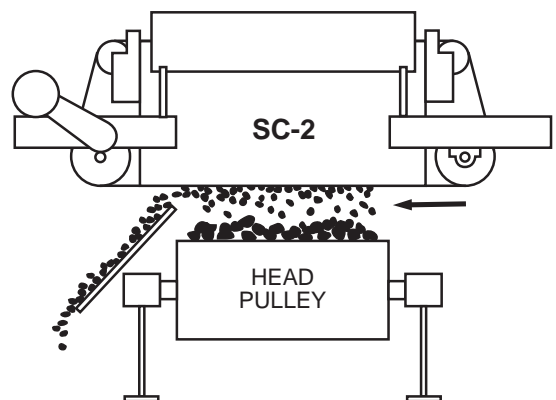

COMPUTER - DESIGNED "SPECIALS"

The Series 7000 suspended electromagnet designs result from a unique computer program developed by Eriez research. For special requirements, the most efficient and economical adaptations of standard models can be computer-designed in minutes.

There are no long deliveries or spiraling costs for tailor-made magnets, and as a result of this capability Eriez has designed and built some of the world's largest and strongest magnets.

FIVE-YEAR WARRANTY

The internal coil assembly on every Series 7000 magnet is warranted for five full years from date of shipment and all other parts are warranted for one year. Eriez magnets have proven they can easily handle day in and day out around-the-clock operation.



Hundreds of manually cleaned Eriez units are in service throughout the world. They are ideal for installation where protection is needed to catch the occasional piece of iron that might contaminate the material flow. This specially designed magnet weighing 65 tons is used over a copper ore conveyor located in Chile.



The Series 7000 magnets can be easily adapted for special applications like this foundry sand reclaiming line. This unit is designed to applications having larger than normal amounts of tramp iron and where the tramp iron is hot, sharp, or large in size. These foundry magnets are equipped with a heavy duty high-temperature belt and oversized drive components as well as heavier frames, bearings and pulley shafts.

A WIDE RANGE OF SUSPENDED MODELS

Eriez builds many types, styles and models of suspended magnets to provide the most efficient magnet for your application.

Eriez became the leader in its field by offering the broadest line of quality equipment at a competitive price backed up by excellent service. In addition to the Series 7000 suspended magnets Eriez can provide:

- Series 6000 permanent non-electric suspended magnets
- Series 800 dry-type suspended electromagnets, Mill Mutual approved

- Series 700U explosion-proof suspended electromagnets — UL listed for Class 1, Division 1, Groups C & D and Class 2, Division 1, Group E, F & G hazardous locations
- Series SE-2400 electromagnets for deep burdens on wide, flat belts or in chutes
- Force cooled and hollow conductor designs include some of the world's most powerful tramp iron magnets

